

***RoHS Compliant***  
**CFast Card Series**  
***Datasheet for Industrial CFast Card***

**August 21, 2012**

Revision 1.3

***This Specification Describes the Features and Capabilities of  
the Standard and Industrial Temperature  
CFast Cards***

***Please Contact Fortasa Memory Systems Sales for any  
Custom Features Required For Your Specific Application***



4151 Middlefield Road  
2<sup>nd</sup> Floor  
Palo Alto, CA 94303 USA  
888-367-8588  
[www.fortasa.com](http://www.fortasa.com)

### Features:

- **Standard Serial SATA 2.6 (Gen 2)**
  - SATA 2.6 command set compatible
  - Serial SATA 2 –3.0 Gbps
  - ATA compatible command set
- **Low power consumption (typical)**
  - Supply voltage: 3.3V±5%
  - Active mode: 360 mA
  - Sleep mode: 85 mA
- **Performance**
  - Sustained read: up to 160 MB/sec
  - Sustained write: up to 140 MB/sec
- **Capacity**
  - 2, 4, 8, 16, 32, 64GB
- **NAND flash type: SLC**
- **MTBF (hours): >2,000,000**
- **Temperature ranges**
  - Operation:
    - Standard: 0 °C to 70 °C (32 ° ~ 158 °F)
    - Industrial: -40 °C to 85 °C (-40 ° ~ 185 °F)
  - Storage: -40 °C to 100 °C (-40 ° ~ 212 °F)
- **Intelligent endurance design**
  - Built-in hardware ECC, enabling up to 16/24 bit correction per 1024 bytes
  - Global wear-leveling scheme together with dynamical block allocation to significantly increase the lifetime of a flash device and optimize the disk performance
  - Flash bad-block management
    - *Power Failure Management*
    - *ATA Secure Erase*
    - *SMART Command*
    - *Trim Command*
- **Connector Type**
  - 7-pin signal connector
  - 15-pin power connector
- **Shock and Vibration**
  - Shock: 1500g (approx.)
  - Vibration: 15g (approx.)
- **RoHS compliant**



---

## Table of Contents

1 Product Description.....	4
1.1 General Description.....	4
1.2 Functional Block.....	4
1.3 Capacity Specification.....	5
1.4 Performance Specification.....	5
1.5 Pin Assignments.....	6
2. Software Interface.....	7
2.1 Command Set.....	7
3. Flash Management.....	8
3.1 Error Correction/Detection.....	8
3.2 Wear Leveling.....	8
3.3 Power Failure Management.....	8
3.4 ATA Secure Erase.....	8
3.5 S.M.A.R.T. Technology.....	8
3.6 TRIM Command Support.....	8
4. Environmental Specifications.....	9
4.1 Environments.....	9
4.2 Mean Time Between Failures (MTBF).....	9
4.3 Certification and Compliance.....	9
5. Electrical Specification.....	10
5.1 Operating Voltage.....	10
5.2 Power Consumption.....	10
6. Physical Characteristics.....	11
6.1 Dimensions.....	11
7. Product Ordering Information.....	12
7.1 Product Code Designations.....	12
7.2 Valid Combinations.....	13
8. Revision History.....	14

## 1 Product Description

### 1.1 General Description

CFast emerged as an evolution of the CompactFlash card standard, by adopting a SATA bus interface to delivers a much higher data transfer rate required in the current generation of industrial and enterprise applications. Offering a substantially higher data throughput rate, CFast proved to be a more advanced embedded solution for cache, storage acceleration, communication and networking applications is a small, compact package.

Fortasa's CFast solution is designed with a powerful Flash controller that easily breaks the performance limit for CompactFlash by delivering the transfer rate up to 160 MB/s. Leveraging from CompactFlash form factor and SATA interface, CFast can be integrated into host computing system without excessive BIOS configurations and driver installations.

In addition to its peak performance, Fortasa CFast is designed with high reliability and data integrity. The CFast card adopts static wear-leveling to average the use of all flash blocks to prolong the lifetime and improve block efficiency of flash media. A built-in powerful ECC engine operates at hardware level for error correction and detection. CFast is an ideal storage device for industrial, enterprise and communication applications.

### 1.2 Functional Block

Fortasa CFast includes a single-chip SATA II Controller and the flash media. The controller integrates the flash management unit to support multi-channel, multi-bank flash arrays. Figure 1-1 shows the functional block diagram.

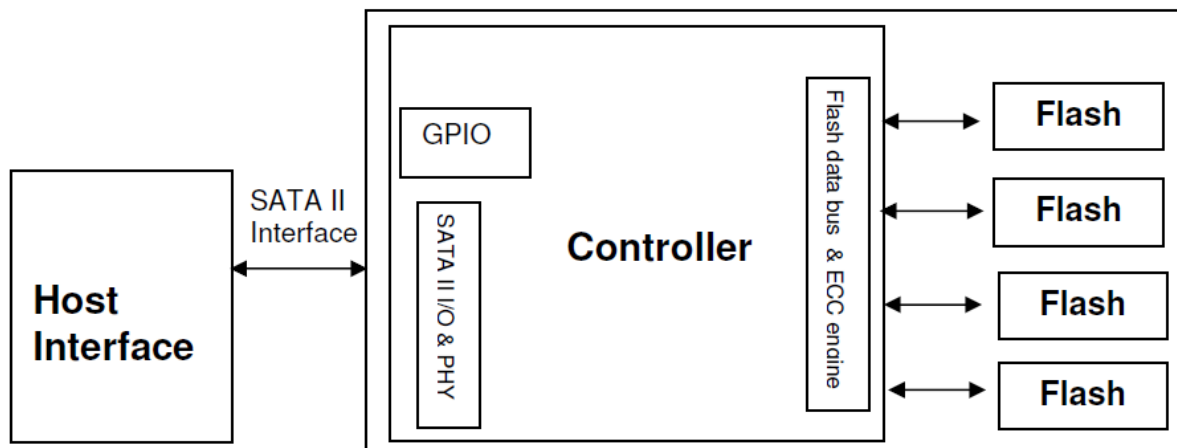

**Figure 1-1:** CFast functional block diagram

### 1.3 Capacity Specification

Standard capacity specification of the CFast product are shown in Table 1-1. The table lists the specific capacity and the default numbers of heads, sectors and cylinders (CHS) for each product line.

**Table 1-1:** Capacity specifications

Capacity	Total Bytes	Cylinders	Heads	Sectors	Max LBA
2GB	2,011,226,112	3897	16	63	3,928,176
4GB	4,011,614,208	7773	16	63	7,835,184
8GB	8,012,390,400	15525	16	63	15,649,200
16GB	16,013,942,784	16383 <sup>1</sup>	16	63	31,277,232
32GB	32,017,047,552	16383 <sup>1</sup>	16	63	62,533,296
64GB	64,023,257,088	16383 <sup>1</sup>	16	63	125,045,424

1. Cylinders, heads or sectors are not applicable for these capacities. Only LBA addressing applies.

*Please contact factory for any non-listed CFast capacity or custom CHS requirement.*

### 1.4 Performance Specification

Performances of the CFast device are listed in Table 1-2.

**Table 1-2:** Standard Performance specifications

Performance \ Capacity	Capacity					
	2GB	4GB	8GB	16GB	32GB	64GB
Sustained read (MB/s)	145	145	150	150	160	160
Sustained write (MB/s)	55	55	100	100	140	140

## 1.5 Pin Assignments

Figure 1-2: Pin Assignment

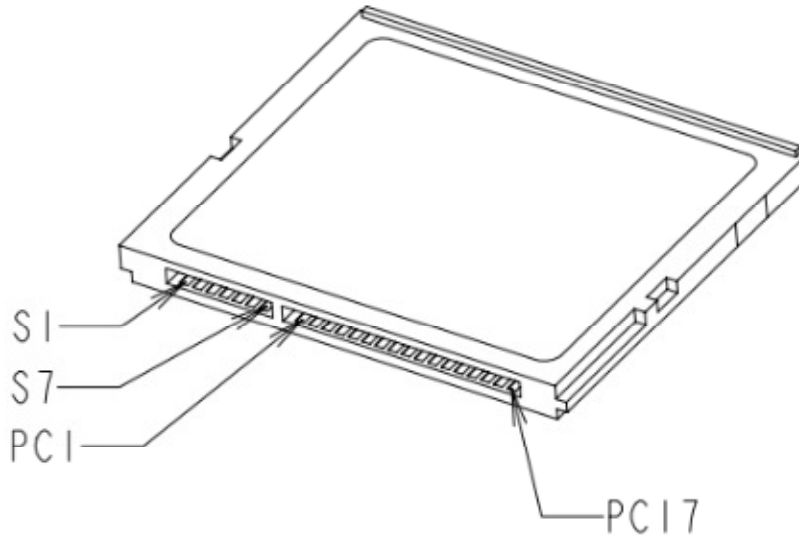
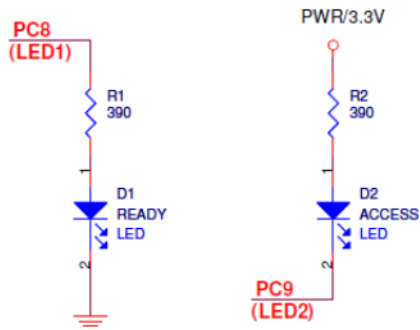

Table 1-3: Signal Segment

Pin	Signal	Description
S1		Ground
S2	A+	SATA Differential Signal Pair A
S3	A-	
S4		Ground
S5	B-	SATA Differential Signal Pair B
S6	B+	
S7		Ground

Table 1-4: Power Segment

Pin	Name	Type	Description
PC1	CDI	CMOS Input	Card Detect In
PC2	GND	Device GND	
PC3	TBD	TBD	
PC4	TBD	TBD	
PC5	TBD	TBD	
PC6	TBD	TBD	
PC7	GND	Device GND	
PC8*	LED1	LED Output	Ready
PC9*	LED2	LED Output	Access
PC10	IO1	CMOS I/O	Reserved I/O
PC11	IO2	CMOS I/O	Write Protect**
PC12	IO3	CMOS I/O	Reserved I/O
PC13	PWR	3.3V	Device Power 3.3V
PC14	PWR	3.3V	Device Power 3.3V
PC15	PGND	Device GND	Device GND
PC16	PGND	Device GND	Device GND
PC17	PGND	CMOS Output	Card Detect Out



\*Refer above for LED output design guide

\*\*Enabled by adjusting the pin "PC11" from high to low active

## 2. Software Interface

### 2.1 Command Set

Table 2-1 summarizes the command set with the paragraphs that follow describing the individual commands and the task file for each.

**Table 2-1:** Command set

<b>Command</b>	<b>Code</b>	<b>Command</b>	<b>Code</b>
Check-Power-Mode	E5H	Security-Erase-Prepare	F3H
Data Set Management	06H	Security-Erase-Unit	F4H
Execute-Drive-Diagnostic	90H	Security-Freeze-Lock	F5H
Flush-Cache	E7H	Security-Set-Password	F1H
Flush-Cache EXT	EAH	Security-Unlock	F2H
Identify-Drive	ECH	Seek	70H
Idle	E3H	Set-Features	EFH
Idle-Immediate	E1H	SMART	B0H
Initialize-Drive-Parameters	91H	Set-Multiple-Mode	C6H
Read DMA	C8H	Set-Sleep-Mode	E6H
Read DMA EXT	25H	Stand-By	E2H
Read-Multiple	C4H	Stand-By-Immediate	E0H
Read-Multiple EXT	29H	Write DMA	CAH
Read-Sector	20H	Write DMA EXT	35H
Read-Sector EXT	24H	Write-Multiple	C5H
Read-Verify-Sectors	40H	Write-Multiple EXT	39H
Read-Verify-Sectors EXT	42H	Write-Sector	30H
Recalibrate	1XH	Write-Sector EXT	34H
Security-Disable-Password	F6H		

---

### 3. Flash Management

#### 3.1 Error Correction/Detection

The CFast implements a hardware BCH-based ECC scheme to achieve up to 16 or 24 bit correction per 1024-byte page.

#### 3.2 Wear Leveling

All NAND flash devices are limited by a finite number of write cycles. Under a standard file system, frequent file table updates are mandatory. As a painful side effect of OS file overhead, some areas of flash address space wear out faster than others. As these certain sections get a substantially higher write occurrence the whole CFast can wear out very quickly. This uneven wear would significantly reduce the lifetime of the whole device, even if majority of the Flash sectors are far from the write cycle limit. Fortasa's CFast products offer advanced data wear leveling which distributes Flash writes evenly across the full memory space. By utilizing this advanced wear leveling feature, the lifetime of the media can be significantly extended.

#### 3.3 Power Failure Management

The Low Power Detection on the Flash controller initiates cached data saving before the power supply to the device drops too low for operation. This feature prevents the device from system crash and ensures data integrity during an unexpected brownout. This feature makes sure that there are no catastrophic failures of the CFast due to system power glitches.

#### 3.4 ATA Secure Erase

Accomplished by the Secure Erase (SE) command, which added to the open ANSI standards that control disk drives, "ATA Secure Erase" is built into the disk drive itself and thus far less susceptible to malicious software attacks than external software utilities. It is a positive easy-to-use data destroy command, amounting to electronic data shredding. Executing the command causes a drive to internally completely erase all possible user data. This command is carried out within disk drives, so no additional software is required. The erase process will not stop until it is completed. In case of power failure, the erase process will continue when the power is reapplied to the device.

#### 3.5 S.M.A.R.T. Technology

S.M.A.R.T. is an acronym for Self-Monitoring, Analysis and Reporting Technology, an open standard allowing disk drives to automatically monitor their own health and report potential problems. It protects the user from unscheduled downtime by monitoring and storing critical drive performance and calibration parameters. Ideally, this should allow taking proactive actions to prevent impending drive failure. Fortasa SMART feature follows the SATA Rev. 2.6, ATA/ATAPI-7 specifications, using the standard SMART command B0h to read data from the drive. And based on the SFF-8035i Rev. 2.0 specifications, Fortasa SMART Attribute IDs represent Initial bad block count, Bad block count, Spare block count, Maximum erase count, Average erase count and Power cycle. When the Fortasa SMART Utility is running on the host, it analyzes and reports the disk status to the host before the CFast is in critical condition.

#### 3.6 TRIM Command Support

Over time the performance of SSD degrades as user continually writes and erases data. The ATA-TRIM command "formats" the SSD to optimize the drive performance. A TRIM enabled CFast card running an OS with TRIM support will stay closer to its peak performance without much performance variance.



## 4. Environmental Specifications

### 4.1 Environments

Environmental specification of the CFast series follows the MIL-STD-810F standard as shown in Table 4-1.

**Table 4-1:** Environmental specifications

Environment		Specification
Temperature	Operation	0°C to 70°C (standard); -40°C to 85°C (industrial)
	Storage	-40°C to 100°C
Vibration		Sine wave: 5~55~5 Hz (X, Y, Z) Random: 10-2000 Hz, 16.3 G (X, Y, Z)
Shock-Operating		Acceleration: 1,500 G, 0.5 ms Peak acceleration: 50 G, 11 ms
Humidity		5% to 95% RH (Non-condensing)

### 4.2 Mean Time Between Failures (MTBF)

Mean Time Between Failures (MTBF) is predicted based on reliability data for the individual components in the SAFD drive. Based on provided component data, CFast is rated at more than 2,000,000 hours.

Notes about the MTBF:

The prediction is based on Bellcore analysis method by assuming device failure rate can be generated by the sum of failure rates in each component.

### 4.3 Certification and Compliance

The SAFD25P complies with the following standards:

- CE – EN55022/55024
- FCC 47CFR Part15 Class B
- RoHS
- MIL-STD-810F
- SATA II (SATA Rev. 2.6)
- Up to ATA/ATAPI-7 (including S.M.A.R.T.)

## 5. Electrical Specification

### 5.1 Operating Voltage

**Caution: Absolute Maximum Stress Ratings** – Applied conditions greater than those listed under “Absolute Maximum Stress Ratings” may cause permanent damage to the device. This is a stress rating only and functional operation of the device at these conditions or conditions greater than those defined in the operational sections of this data sheet is not implied. Exposure to absolute maximum stress rating conditions may affect device reliability.

**Table 5-1:** Operating range

Range	Ambient Temperature	Conditions
Commercial	0°C to +70°C	3.135 V – 3.465 V
Industrial	-40°C to 85°C	

### 5.2 Power Consumption

Table 5-2 lists the CFast power consumption.

**Table 5-2** CFast power consumption (typical)

Performance \ Capacity	2GB	4GB	8GB	16GB	32GB	64GB
	<b>Active Mode (mA)</b>	255	255	320	345	325
<b>Stand-by Mode (mA)</b>	80	85	85	85	85	85

## 6. Physical Characteristics

### 6.1 Dimensions

Figure 6-1 illustrates the overall dimensions of the CFast card, as listed in Table 6-1.

**Table 6-1** CFast dimensions

Dimension	Millimeters (mm)
Length	$36.40 \pm 0.15$
Width	$42.80 \pm 0.10$
Height	3.6 mm (MAX)

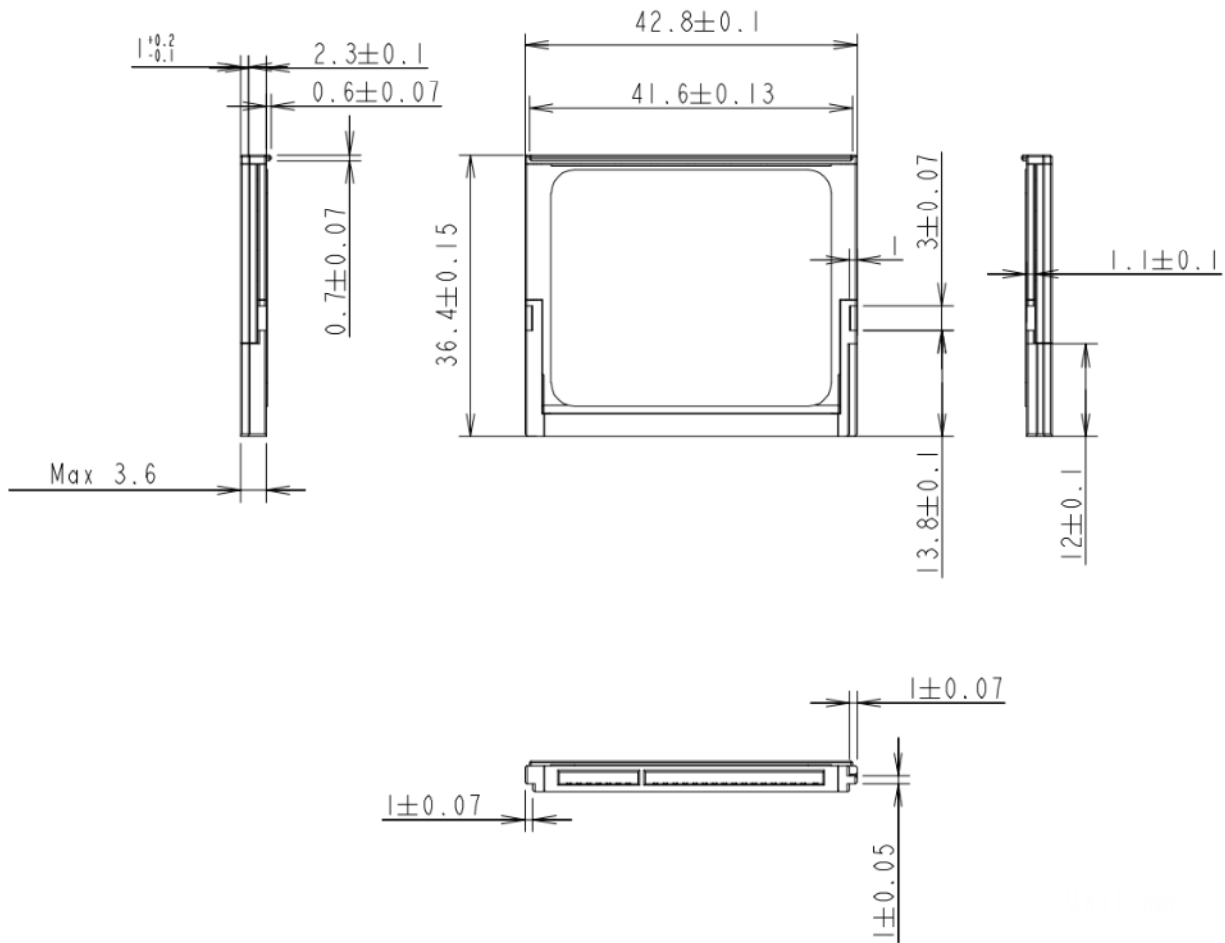

Unit: mm

## 7. Product Ordering Information

### 7.1 Product Code Designations

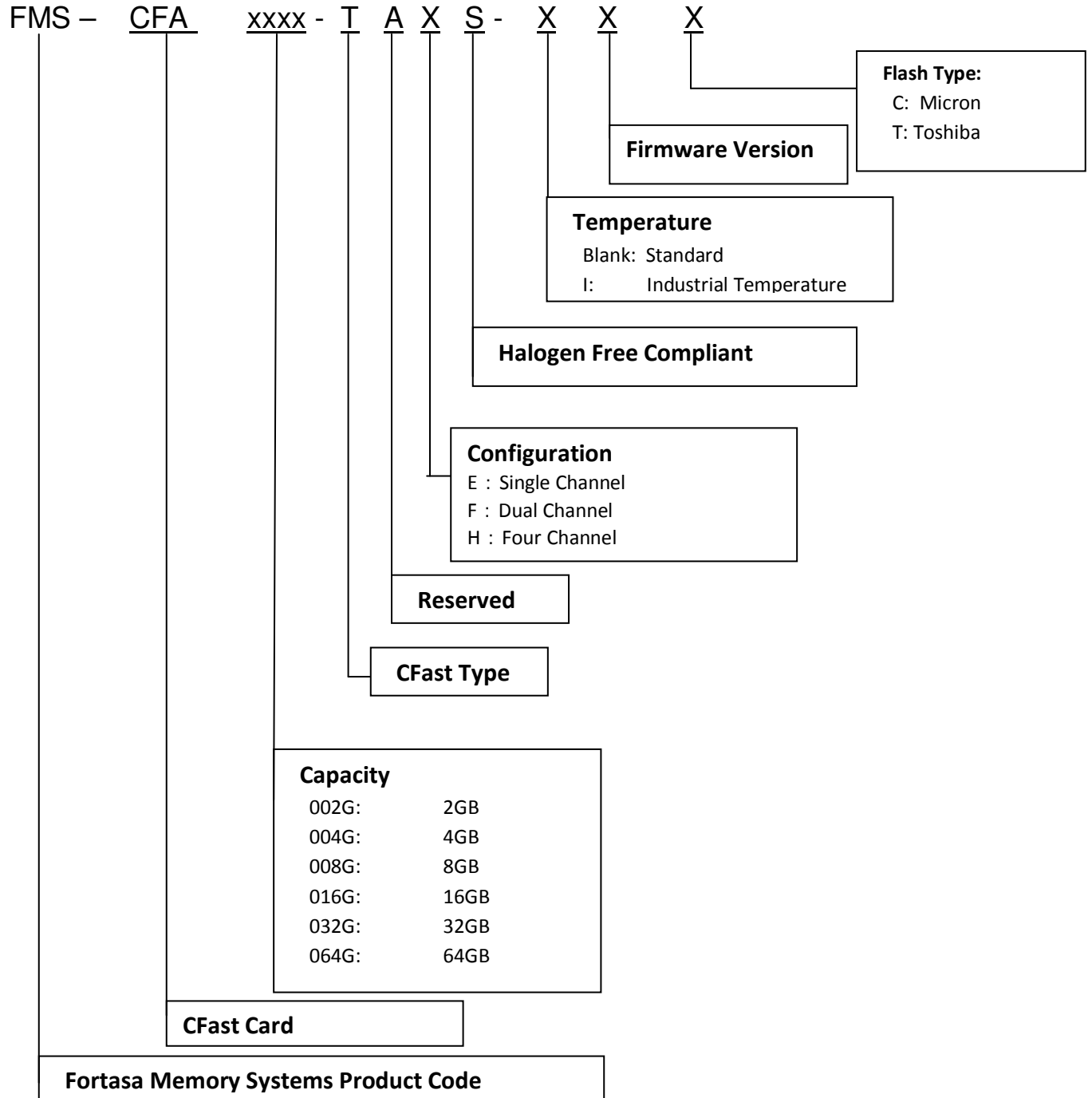

### 7.2 Valid Combinations

Capacity	Standard Temperature Model Numbers	Industrial Temperature Model Numbers
2GB	FMS-CFA002GTAHS-CT	FMS-CFA002GTAHS-ICT
4GB	FMS-CFA004GTAHS-CT	FMS-CFA004GTAHS-ICT
8GB	FMS-CFA008GTAHS-CT	FMS-CFA008GTAHS-ICT
16GB	FMS-CFA016GTAHS-CT	FMS-CFA016GTAHS-ICT
32GB	FMS-CFA032GTAHS-CC	FMS-CFA032GTAHS-ICC
64GB	FMS-CFA064GTAHS-CC	FMS-CFA064GTAHS-ICC

**Note:** Valid combinations are those products in mass production or will be in mass production. Consult your Fortasa sales representative to confirm availability of valid combinations and to determine availability of new product combinations

---

## 8. Revision History

Revision	Date	Description	Comments
1.0	5/20/2012	Initial Release	
1.1	5/29/2012	Added notes about hardware write protect in pin assignment Revised General Description	
1.2	8/14/2012	Corrected Marketing Part Numbers	
1.3	8/21/2012	Added 2GB device	